

E-Organisationsbeschlag

Public
Mod.-No.

E-Organisation plate

80510

Ferrure d'organisation E

80550

Ferramenta di organizzazione E

Dok-Nr. 235599

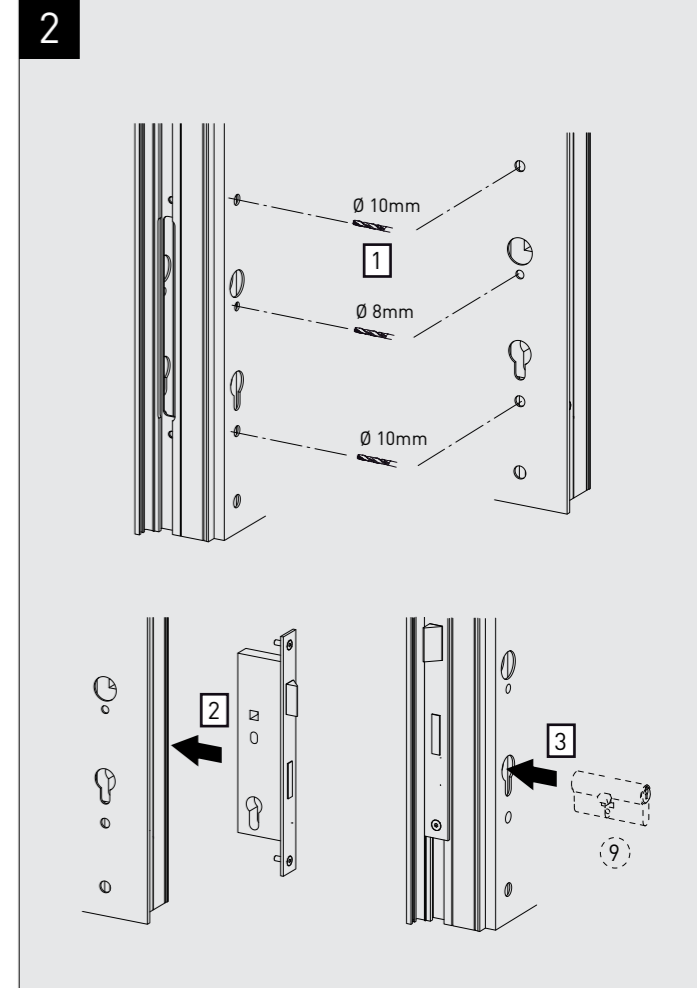
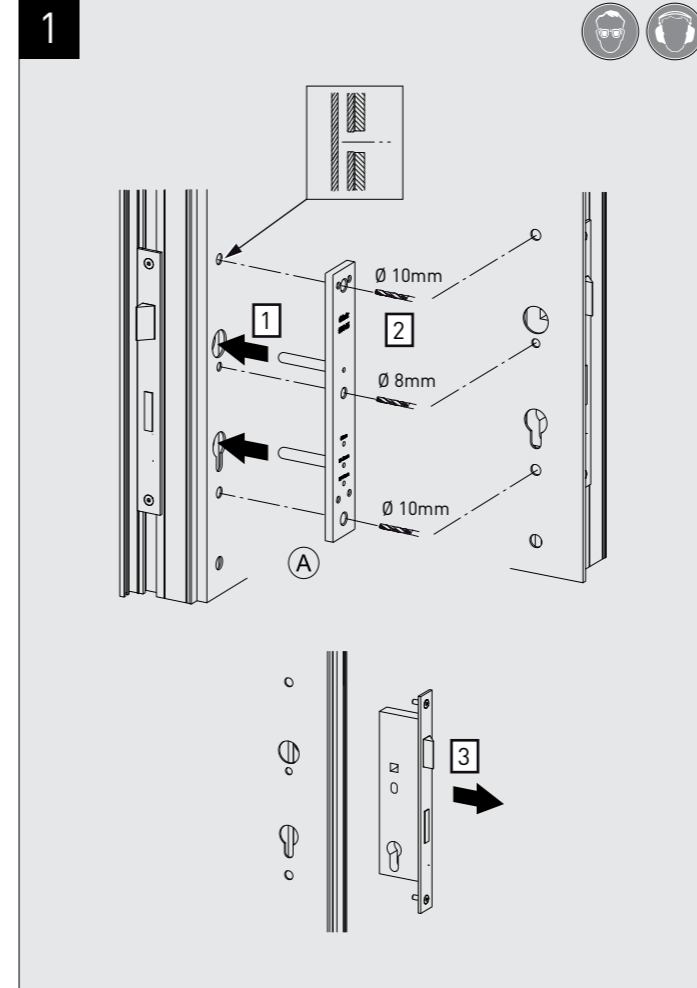
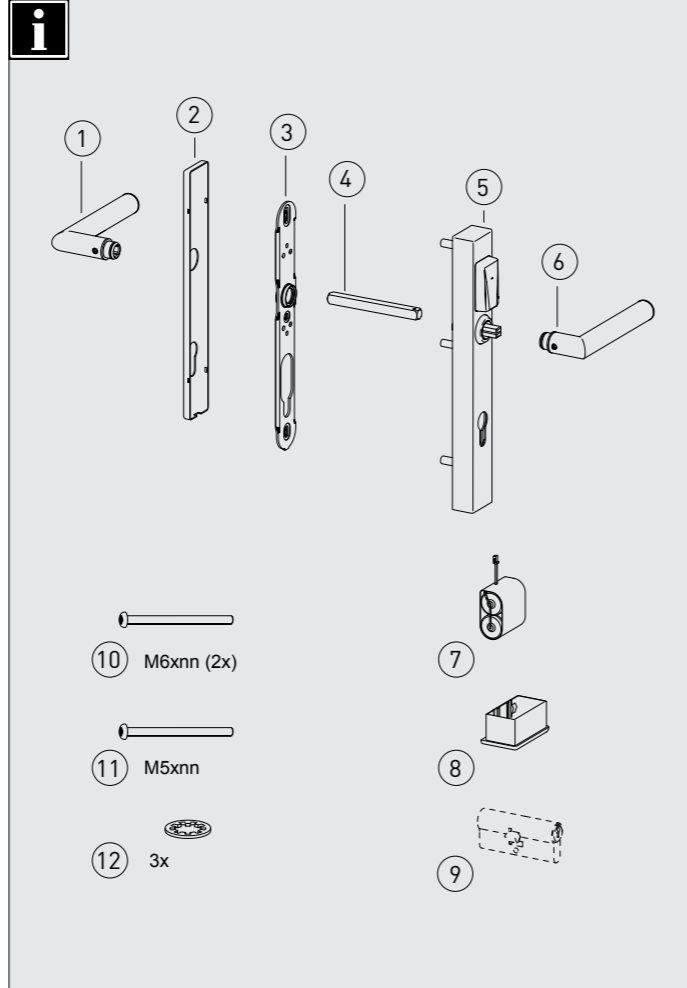

DE Bei Arbeiten mit der Bohrmaschine sind Schutzbrille und Gehörschutz zu tragen.



Ketten, Ringe und störende Kleidungsstücke (Schal, Handschuhe, lange Ärmel, etc.) sind vor dem Bohren auszuziehen.



Um Beschädigungen am Schloss zu vermeiden, ist das Schloss vor dem Bohren auszubauen.

FR Lors des travaux réalisés avec une perceuse, porter des lunettes de sécurité et un casque.



Avant les perçages, retirer les chaînes, les bagues et les vêtements gênants (foulard, gants, vêtements à manches longues, etc.).



Pour ne pas endommager le système de fermeture, le démonter avant les perçages.

EN Wear safety glasses and hearing protection when working with a drill.



Bracelets, chains, rings, and interfering clothing (i.e. scarves, gloves, long sleeves, etc.) must be removed before drilling.



To avoid damaging the lock, dismantle it before drilling.

IT In caso di lavori con il trapano, è necessario indossare occhiali protettivi e una protezione per l'udito.



Collane, anelli e parti di indumenti ingombranti (sciarpe, guanti, maniche lunghe ecc.) devono essere rimossi prima della perforazione.



Per evitare danni alla serratura, smontarla prima di eseguire la perforazione.

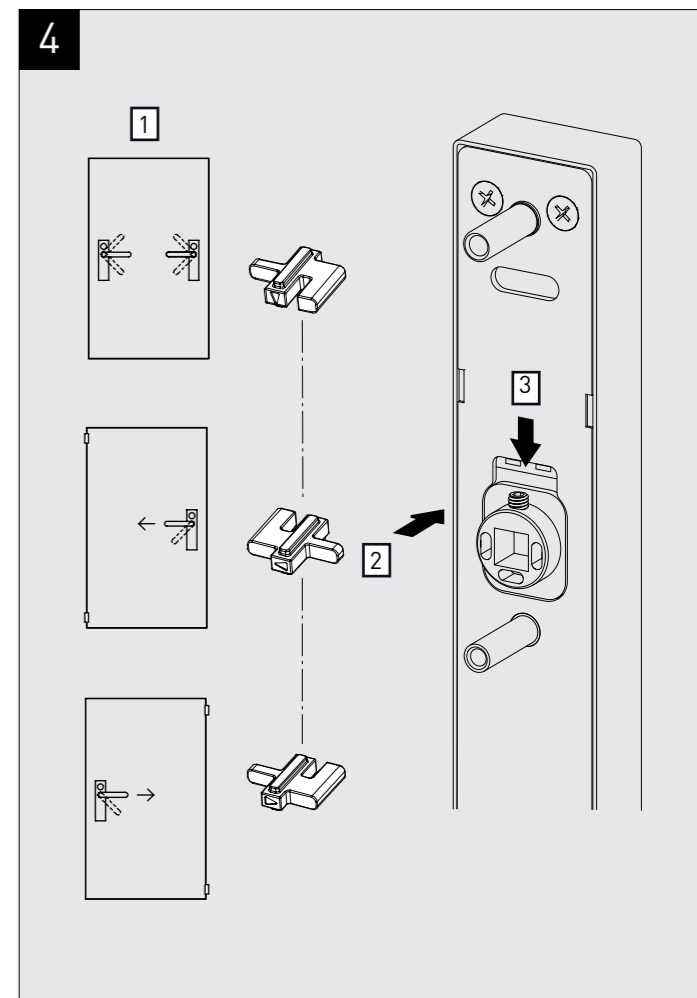
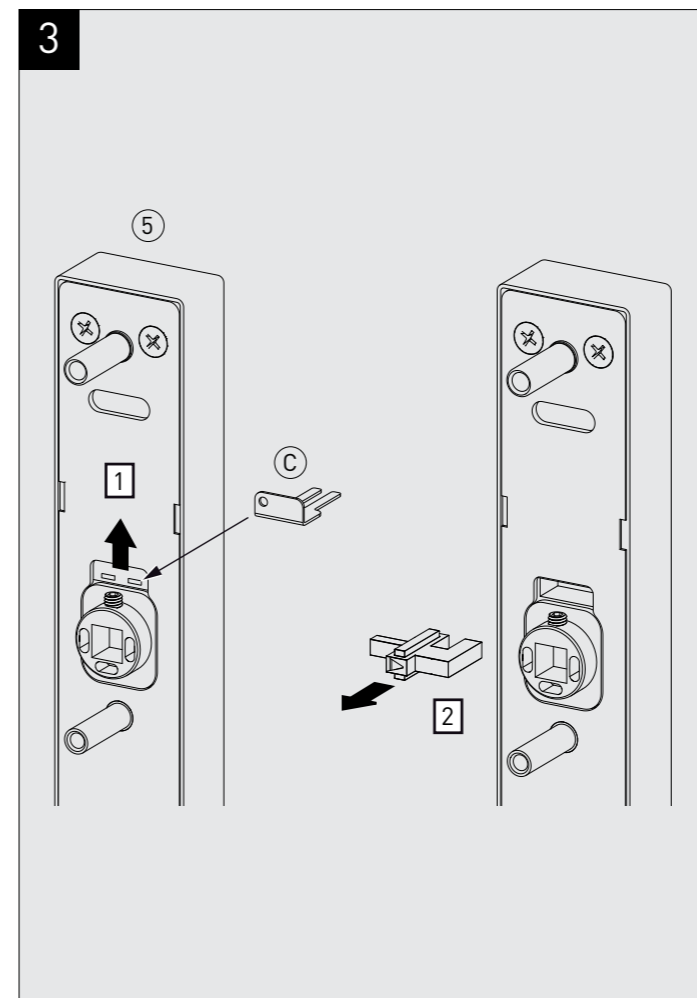
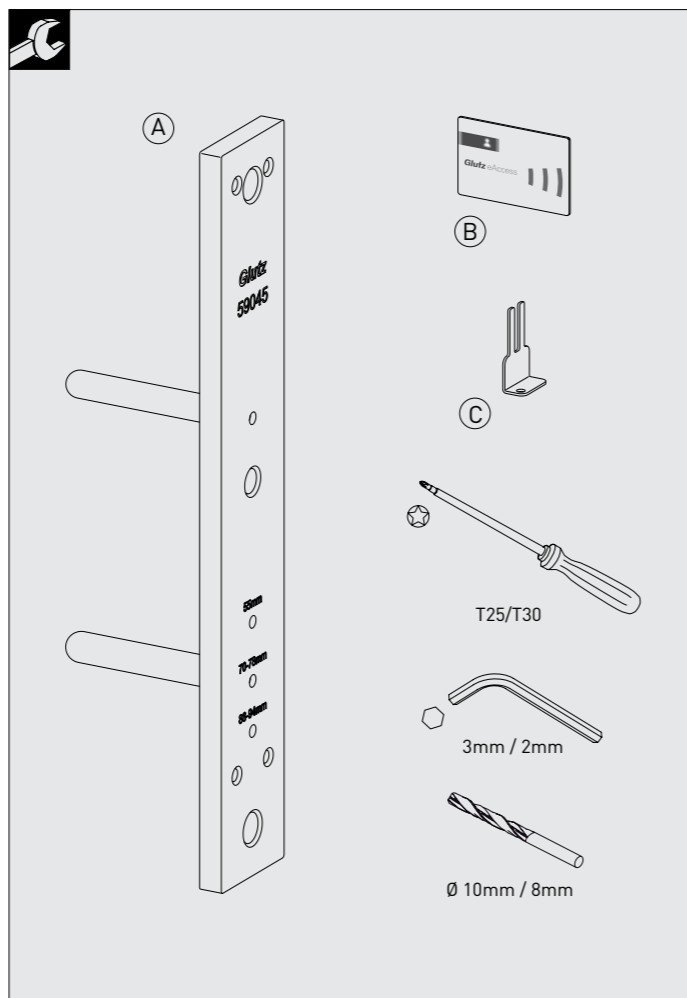

5

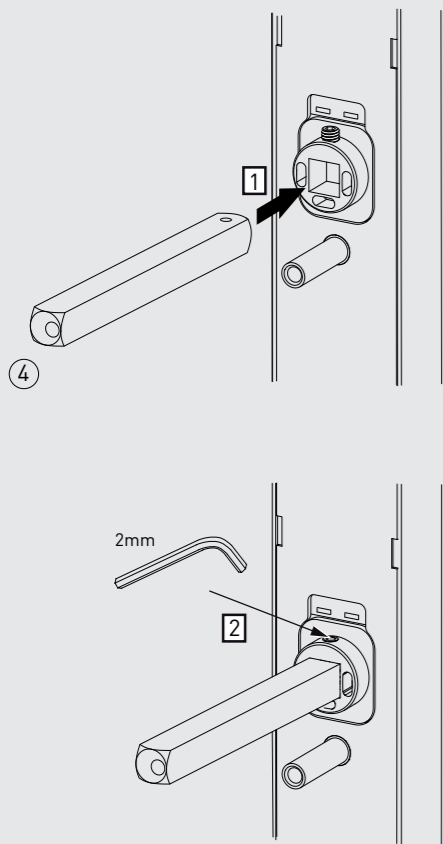

6

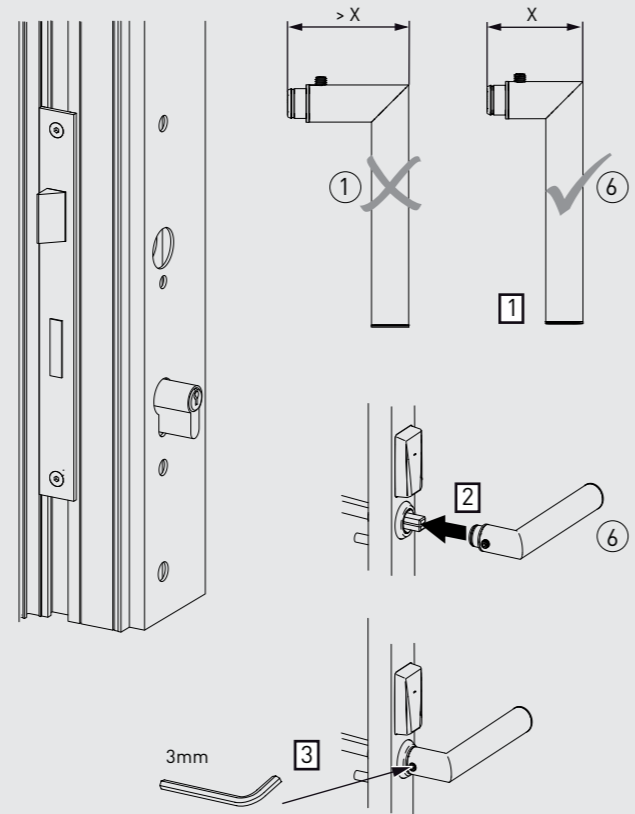

7

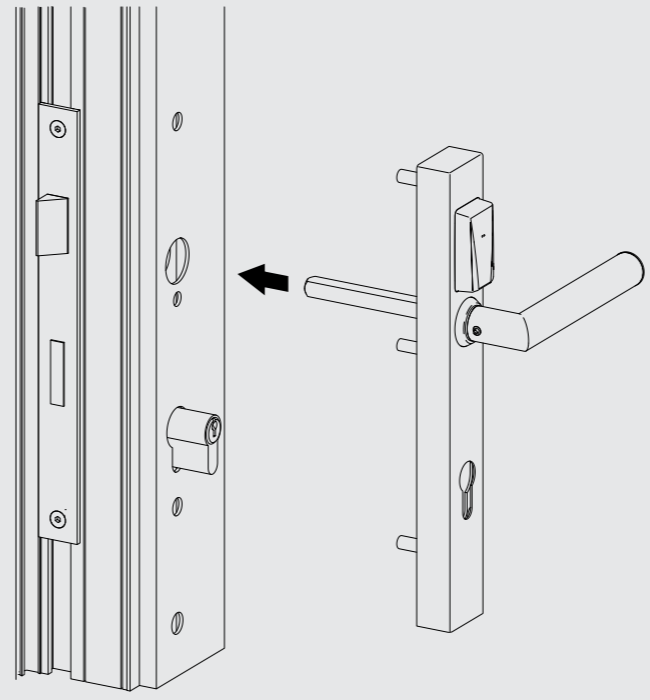

8

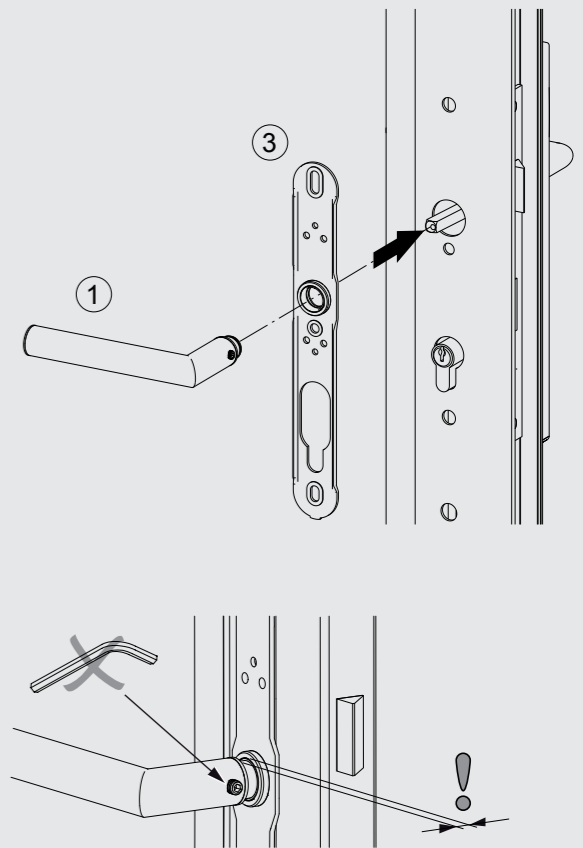

9

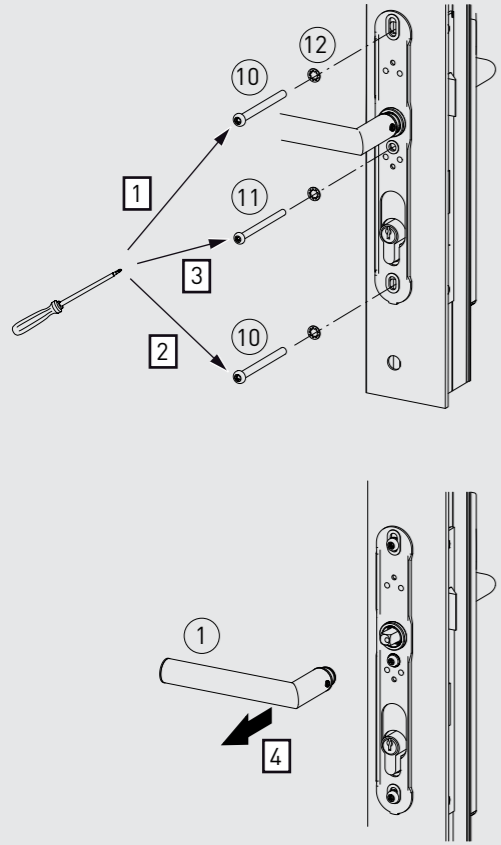

10

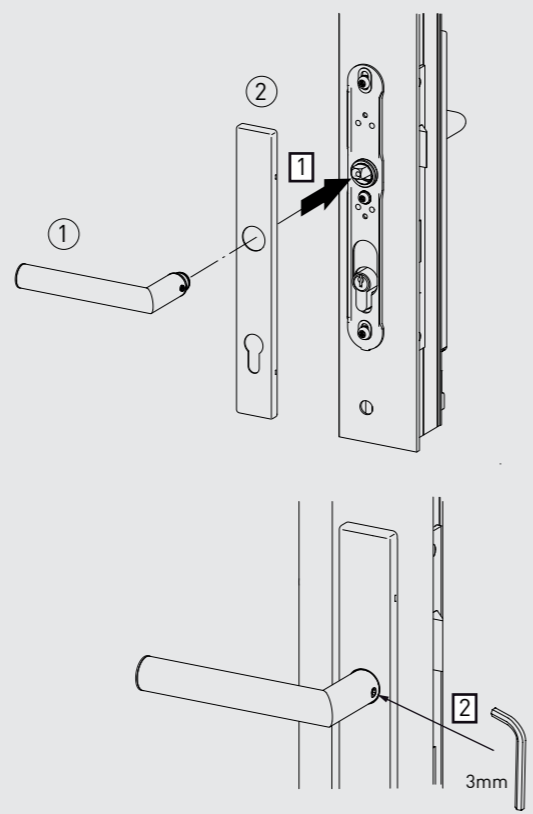

11

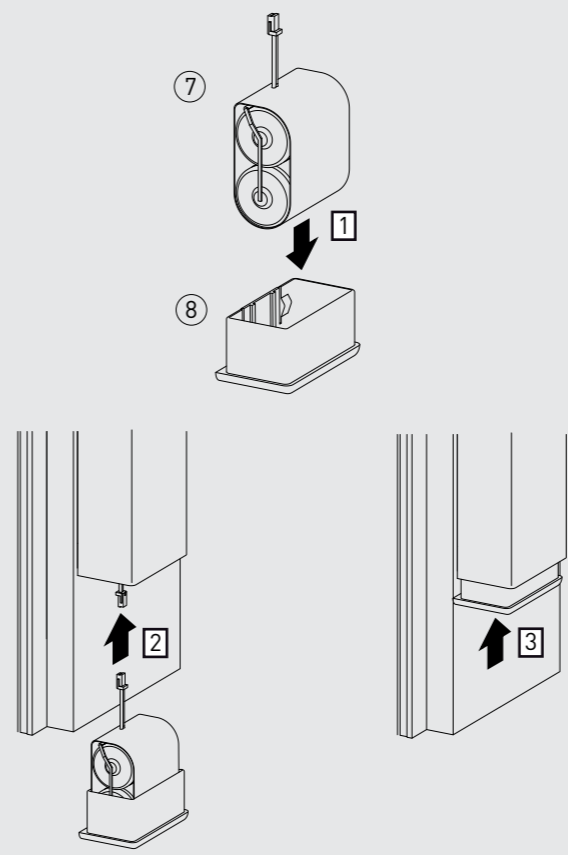

12

